

# New Audio/Video Opportunities for IEEE 1394-enabled Personal Computers

**Rob Laubscher**  
Software Engineer  
Digital Harmony Technologies, Inc.  
Seattle, Washington, USA

**Greg Bartlett**  
Co-Founder and Chief Executive Officer  
Digital Harmony Technologies, Inc.  
Seattle, Washington, USA

## Abstract

The IEEE 1394 bus is rapidly becoming the digital interconnection standard of choice. New applications have emerged for IEEE 1394-enabled PCs, due to the rapid proliferation of 1394 digital camcorders, hard disk drives, scanners and printers. The use of IEEE 1394 in audio/video production studio environments is introduced, and shown to have many benefits to amateur and professional filmmakers, musicians and composers. Recommendations are made for the computer and semiconductor industries to consider this market and the relevant protocols that exist, so that personal computers are designed to work in harmony with other audio and video devices in the IEEE 1394 professional and project studio environments.

## Introduction

PCI, ISA, VESA, IDE, and SCSI are some of the existing interconnection standards found in personal computers ("PCs") today. Manufacturers are constantly developing bigger, better and faster interconnection technologies, to bolster sales of new products in the "application-pull, technology-push" electronics and computing industries. In this relationship, hardware and software drive each other. As new hardware is developed allowing newer applications, newer software applications emerge requiring improved hardware. Multimedia applications push PC resources to their limits, due to the fact that today's hardware design was firmly established before developers considered the data throughput necessary for tomorrow's multimedia applications. Hardware designers respond with faster internal busses and peripheral connection, e.g., replacing ISA and EISA buses with PCI, and IDE with faster SCSI.

Engineers at Apple Computer recognized the need for a serial interface standard that could accommodate the increasing data demands of audio and video applications. Their development effort resulted in "FireWire", the technology that became IEEE standard 1394-1995.

Immediately identifying the benefits of the 1394 bus in digital video applications, Sony was first to market a 1394-enabled digital camcorder – in fact, the first IEEE 1394 consumer product. Sony's Digital Video Cassette ("DVC") camcorder achieved better quality at one-third the cost of a professional Betacam SP component system. Their 1394 implementation allowed a direct digital link

to a 1394-equipped PC. For the first time, lossless non-linear video editing could be performed by software running on a PC, eliminating the need for an expensive editing desk. A new era of desktop digital video editing had been born. This fact was not lost on Apple Computer, who quickly identified "desktop movies" as the application that would become their "desktop publishing" of the new millennium.

As can be seen from the number of 1394-enabled computers, peripheral connectivity is also changing. The Serial Bus Protocol 2 ("SBP-2") is an asynchronous memory-mapped transport protocol used to transport existing device protocols such as SCSI over the IEEE 1394 bus. The memory-mapped nature of this protocol, and indeed the IEEE 1394 bus architecture itself, allows efficient implementation in a direct memory access ("DMA") device architecture. Devices such as hard disk drives, scanners and printers that utilize SBP-2 offer high performance and ease of use. They can be easily attached or removed from the host computer, plug-and-play. Support for the SBP-2 protocol is provided in popular operating systems including Microsoft Windows, Apple OS, and soon Linux.

## **IEEE 1394 in Audio/Video Production Studios**

The emerging desktop movies market and the popularity of online music distribution are also changing the audio and audio-for-video production studio. To produce the music that has become so much a part of our everyday lives, composers, producers and recording engineers utilize a variety of electro-acoustic devices, connected via a plethora of cabling. This collection of devices and the accompanying mass of interconnecting cables constitutes what is known as a production studio. Part of the complexity of sound production in a studio arises from the many different standards used for device interconnectivity. Many studio devices can be controlled via a software and hardware standard called MIDI (Musical Instrument Digital Interface). Devices utilizing MIDI exchange messages to communicate performance data (instructing sound generators to produce sounds), configuration data (used for setting the parameters of devices), and timing information.

There are different types of production studios, each geared towards the final product that emerges. The type of studio that is considered in this paper is referred to as a "project studio". A project studio will typically enable a composer, producer or recording engineer to produce music, perhaps combining acoustic and synthesized sounds. The advent of MIDI and MIDI sequencers (devices that record, timestamp, and playback MIDI messages during a performance) enables a project studio user to create complete musical recordings using a musical space of rich timbres. MIDI can further be utilized to automate studio devices and provide control of devices from a central point.

MIDI has recognized limitations, in particular its low bandwidth and resulting transmission latencies. The widespread adoption of MIDI however, requires users to compromise.

A PC often plays an integral part in a project studio, with contemporary software being able to facilitate the generation, recording, and processing of sounds. A PC used in this environment is often called a “digital workstation”. Besides MIDI sequencing, today’s powerful and fast PCs can now also assume the task of digital audio recording, audio processing, and even software synthesis.

The problems found in studios are still present in a digital workstation environment: devices are still connected by a “spaghetti” of wiring, both for audio and MIDI data. This is compounded by different standards, as is the case with digital audio. To solve these problems, a new connection standard is desired that satisfies the following criteria:

- Supports digital multi-channel audio and MIDI data distribution;
- Allows integration with digital workstations;
- Encapsulates methods for routing audio and MIDI data between devices;
- Guarantees synchronization between connected devices;
- Supports interoperability between multiple vendors;
- Requires minimal user effort to add or remove devices;
- Is cost effective;
- Offers the highest level of performance;
- Is robust and reliable;
- Utilizes an open standard.

The IEEE 1394 High Performance Serial Bus provides a welcome solution for studio device interconnectivity. The 1394 bus can be considered as a hybrid interconnectivity and networking technology. Simple point-to-point cables in a flexible topology connect devices. The combined point-to-point connections between nodes are utilized by application protocols to create a high performance network bus. At a glance, the 1394 bus offers the following features:

- Up to 400Mbps data transfer rate;
- Up to 63 nodes per bus, and up to 1023 interconnected buses;
- Hot plugging and true plug and play, including auto-configuration and optimization;
- Power distribution in the cable – if a node’s power requirements are modest, they may draw their power to operate directly from the 1394 bus;
- A verified packet transmission mechanism (asynchronous transactions);
- A guaranteed latency, reserved bandwidth data transmission mechanism (isochronous transactions);
- Mechanisms for broadcasting, multi-casting and single-destination data transmission;
- No master controller is required in a 1394 system, eliminating the communications bottleneck and single point of failure common to many other systems such as USB.

Isochronous transactions are a key feature of the 1394 bus, causing it to be labeled “the multimedia connection”. The guaranteed low transmission latency of isochronous transactions enables “just in time” delivery of audio and video data. The distribution of a common clock and bandwidth reservation mechanisms further enhance the usability of isochronous transactions for audio/video applications.

Realizing the potential for audio and MIDI data distribution using isochronous transactions, Yamaha Corporation developed the mLAN (music Local Area Network) specification [8]. The mLAN specification extended an existing international standard (IEC 61883) for digital video distribution using the 1394 bus, to accommodate audio and MIDI data. The Audio Engineering Society (“AES”) established the *SC-06-02 Working Group on IEEE 1394* to establish standards for transmitting audio over the 1394 bus. The mLAN specification subsequently evolved into the Audio and Music Data Transmission Protocol (A/M protocol), which is currently being finalized for incorporation into the IEC 61883 standard suite as IEC 61883-6 [10].

The IEC 61883-6 streaming specification, together with the suite of AV/C (Audio Video Control) control protocols developed by the 1394 Trade Association, form the basis for production studio media streaming and control protocols, respectively. Integrating a 1394-enabled PC into this environment enables existing digital workstation software to be utilized in a production environment that is characterized by ease of use and high performance.

The commercial and technical success of the 1394 interface on studio devices depends on three main factors: the architectural design of integrated silicon node controllers; the availability of tested firmware that implements the myriad international standards and protocols for studio devices; and device certification—the final “seal of approval” that tells the user that the studio device will work in harmony with other audio/video devices already present in the production studio.

## **Audio and Music (“A/M”) Data Protocol**

IEC61883-6 specifies an audio and music data transmission protocol used for transmitting audio and music data over IEEE 1394. Audio and music data are encapsulated within packets according to the Common Isochronous Protocol (CIP) format described in IEC 61883-1 [9]. The CIP provides a mechanism for mapping audio/video data types into IEEE 1394 isochronous transactions, as well as a time stamping mechanism that enables a constant transport delay and reconstruction of the application packet timing.

IEC61883-6 prescribes a particular isochronous packet header format, and CIP packet header format, with certain fields having information specific to the A/M protocol. There are two transmission methods, non-blocking and blocking. When using the non-blocking method, the transmitter transmits all waiting events as a CIP packet within the current isochronous cycle. The number of data blocks within the CIP packet may vary. When using the blocking transmission method, the transmitter must always wait until there are a particular number of events before it constructs a CIP packet and transmits it. The number of data blocks within the CIP packet remains constant.

The header of a CIP packet includes a time stamp, which if valid indicates the presentation time of a particular event within a multi-event CIP packet. A receiver can read these time stamps and use them for estimating the timing of events between the time stamps; a Phase Locked Loop (“PLL”) may be used for this estimation. It is crucial that the jitter in the clock signal generated by the PLL be minimized, to maintain optimum audio quality. More information on sample clock jitter from audio transmitted over the IEEE 1394 bus is provided by references [3] and [6].

The A/M protocol provides a means of transmitting multiple channels of audio and multiple MIDI sequences, as well as other data. If the components of these various sequences are considered to be events, and if these events are synchronized, then synchronous events can be grouped into ordered collections known as clusters. An isochronous stream can contain a sequence of these clusters (known also as cluster events and data blocks). The events that comprise these clusters are described via 32-bit quadlets known as *AM824 data elements*, so named because they each have an 8-bit label field and 24 bits of data. When a cluster (or data block) contains AM824 quadlets of more than one data type, it is known as a compound cluster (or compound data block).

The IEC61883-6 enhancements prescribe a particular ordering for these quadlets. For example, AM824 quadlets containing IEC 60958-compliant digital audio data will appear before quadlets containing raw audio data; AM824 quadlets containing MIDI data will appear after these.

The bandwidth requirements of a MIDI sequence do not warrant a position within every data block of an isochronous stream. Roland Corporation has proposed a mechanism to utilize a single data block position for multiplexing several MIDI sequences [7]. This mechanism utilizes the fact that a fixed number of data blocks occur between successive time stamped data blocks. Each of several MIDI sequences is assigned one of these time-related positions. Thus, the events within a particular MIDI sequence are not only assigned a particular position within each data block, but they are also assigned a particular data block within a time-ordered sequence.

## Implementation challenges

A key challenge for properly implementing a 1394 production studio device is to properly recover sample clock timing from the IEC 61883-6 CIP timestamps with minimal jitter. This is a requirement of professional audio production. Typically, a DSP or RISC processor is employed as a host processor connected to a 1394 Link Layer Controller integrated circuit, along with sample clock recovery circuitry that is often complex and expensive.

The firmware running on each 1394 device in a system must implement the myriad of open standards that are applicable to the device type. A studio user needs assurance that a new device will interoperate with other devices in the system. Compatibility among multiple manufacturers is a big concern of studio equipment users. Digital Harmony Technologies offers a Device Certification Program for 1394-enabled studio devices [13].

The first silicon device to comply with the Digital Harmony Studio Protocol Suite™—a family of open, international standards and protocols—is being designed under license by Cirrus Logic for their Crystal Semiconductor brand [14]. A block diagram is shown in Figure 1. Expected features of Crystal's Digital Harmony-compliant node controller include:

- On-chip ARM7TDMI microcontroller with on-chip SRAM;
- Audio/Video optimized link layer controller;
- Low jitter CIP packet time stamp processor (real-time clock recovery);
- High speed byte-wide DV video and MPEG port;
- Multi-channel, multi-format audio port;
- DTCP copy protection encryption and decryption;
- Memory port for Digital Harmony Protocol Suite™ 1394 firmware;
- Host microcontroller port for simple set-up and control;
- Standard IEEE 1394 PHY/LLC interface.

The interface to the IEEE 1394 bus is via a standard PHY/LLC port. An on-chip ARM7TDMI controller performs bus management tasks, freeing the host system CPU from any IEEE 1394-specific operations. A DTCP encryption/decryption processor is included. Host control is via a simple register based interface. Digital Harmony™ firmware (IEEE 1394-compliant) is provided to run on the ARM7TDMI; support for all common audio and video protocol standards is included. The Digital Harmony firmware is upgradeable over the 1394 bus, thus allowing compliance with future standards. The audio port can handle more than 8 channels of digital audio data, while the video port can handle multiple video formats, including MPEG2-TS and DV.

## PC 1394 hardware and drivers

A typical 1394-enabled PC will consist of an OHCI (Open Host Controller Interface) Link Layer Controller, optimized for the PCI and DMA architecture of the PC [12], and any Physical Layer chip. Drivers are provided for OHCI-based cards in popular operating systems including Microsoft Windows, Apple OS, and soon Linux.

Microsoft's digital audio initiative facilitates a PC audio model that strives for simplicity, flexibility, and optimal performance. The concept behind the digital audio initiative is to facilitate a PC audio model where all audio mixing and routing is done in the digital domain. Using a completely digital system allows the possibility of using an external digital bus to transfer audio. This offers two advantages – the simplification of developing high-fidelity productions removed from the electrically noisy PC enclosure, and the possibility of plug and play audio modules. The digital audio initiative makes provision for audio to be routed to PCI, USB (Universal Serial Bus), and IEEE 1394 devices.

The digital audio initiative is enabled by the audio architecture found in Microsoft's Win32 Driver Model (WDM) [11]. In the Digital Harmony Studio™ WDM driver system, drivers converge the OHCI 1394 bus driver with the WDM media system, presenting a standard multimedia streaming and control interface to application software. The architecture of the Digital Harmony Studio™ driver system is illustrated in Figure 2.

The Digital Harmony Studio™ WDM driver system consists of a number of modules, each performing control, streaming or operating system interface functions. Modules are included for managing media routing between devices; other modules manage latency in the system, ensuring inter- and intra-media time alignment within the production system. Interfaces are also provided for application software to control parameters found in connected IEEE 1394 devices.

For the control and media streaming system in a production studio environment to be technically successful, it is crucial that target devices implement a consistent set of control and media streaming protocols. Digital Harmony Studio™ firmware implements a suite of open standards that enable all control aspects within a production studio environment. The architecture of the firmware stack, which can run on the upcoming Cirrus Logic/Digital Harmony node controller integrated circuit, is illustrated in Figure 3. Digital Harmony's test certification program ensures that devices bearing the Digital Harmony logo will seamlessly interoperate with other devices and the WDM driver system.

## Conclusion

IEEE 1394 offers the digital media production industry a robust, cost effective, extensible, high speed interconnect for a wide variety of applications. IEEE 1394-enabled PCs play an important role in these applications. IEEE 1394-enabled production studios are a new emerging application that will do for media production what IEEE 1394 has already done for desktop video editing. Prototype Digital Harmony Studio™ systems, with PCs implementing WDM driver systems, are currently demonstrating the viability of concepts presented in this paper. The technical and commercial success of the production studio application depends on all devices correctly implementing a consistent selection of control and media streaming protocols. Cirrus Logic's Crystal Semiconductor forthcoming node controller integrated circuit is a silicon solution that – together with Digital Harmony firmware – meets this requirement.

## Author Contact Information

Rob Laubscher  
Digital Harmony Technologies  
95 Yesler Way, Seattle WA 98104 USA  
+1 206 682 3600 phone  
+1 206 682 7705 fax  
rob@digitalharmony.com

Greg Bartlett  
Digital Harmony Technologies  
95 Yesler Way, Seattle WA 98104 USA  
+1 206 682 3600 phone  
+1 206 682 7705 fax  
greg@digitalharmony.com

## References

- [1] 1394 Trade Association, AV/C Digital Interface Command Set, Version 3.0.
- [2] 1394 Trade Association, Specification for Audio and Music Data Transmission, Version 1.0.
- [3] Hirotaka Kuribayashi, Yasushi Ohtani, and Jun-ichi Fujimori. A supplement to Audio and Music Data Transmission Protocol over IEEE 1394: SMPTE time code transmission, Annex A - Delay and jitter evaluation of an audio clock on IEEE 1394.
- [4] IEEE Std 1394-1995, Standard for a High Performance Serial Bus.
- [5] ISO/IEC 13123:1994, Control and Status Register (CSR) Architecture for Microcomputer Buses.
- [6] Julian Dunn, *Sample clock jitter and real-time audio over the IEEE1394 high performance serial bus*. Available online at <http://www.nanophon.com>.
- [7] Roland Corporation, *Specification for IEEE1394 Media Adaptation Layer for MIDI Data Streams*, Version 0.6.
- [8] Yamaha Corporation, proposal for Audio and Music Protocol, Draft Version 0.32, (August 1996)
- [9] IEC 61883-1, Digital Interface for Consumer Audio/Video Equipment, Part 1, General.
- [10] IEC 61883-6 (PAS), Digital Interface for Consumer Audio/Video Equipment, Part 6, Audio and Music Data Transmission.
- [11] Microsoft, Kernel Mixer and WDM Architecture, 1998. Available online at <http://www.microsoft.com/hwdev/audio/kmixer.htm>
- [12] 1394 Open Host Controller Interface Specification, Release 1.1 (January 2000). Available online at <http://www.microsoft.com/hwdev/1394/>
- [13] <http://www.digitalharmony.com>
- [14] <http://www.cirrus.com>

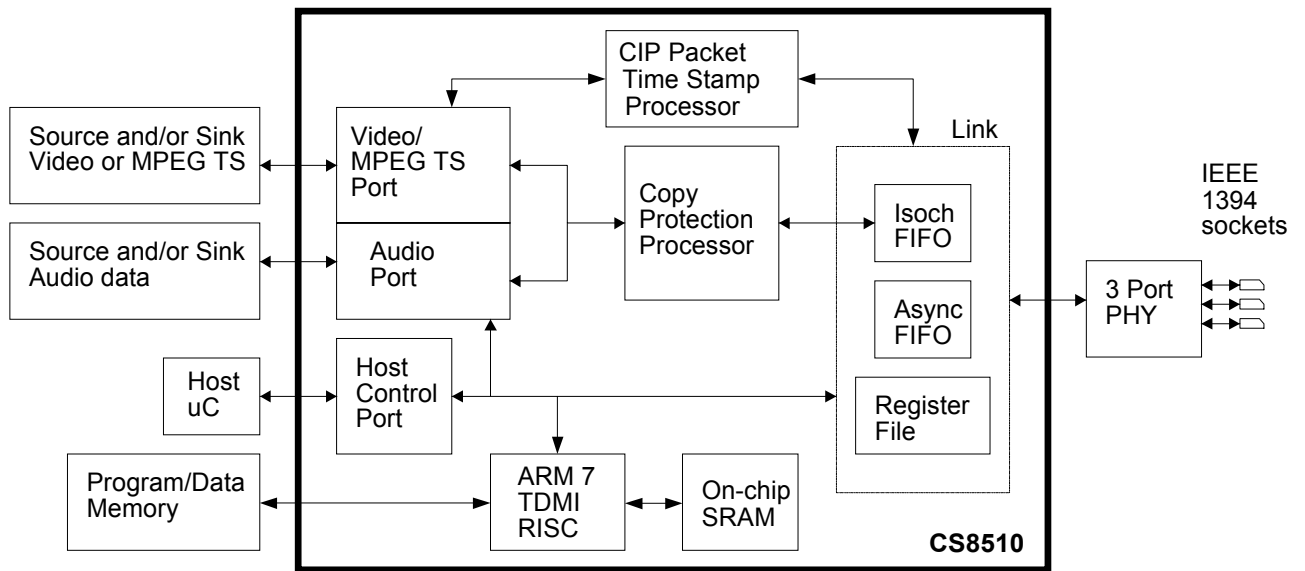

Figure 1: Block diagram of Cirrus Logic/Digital Harmony IEEE 1394 Node Controller

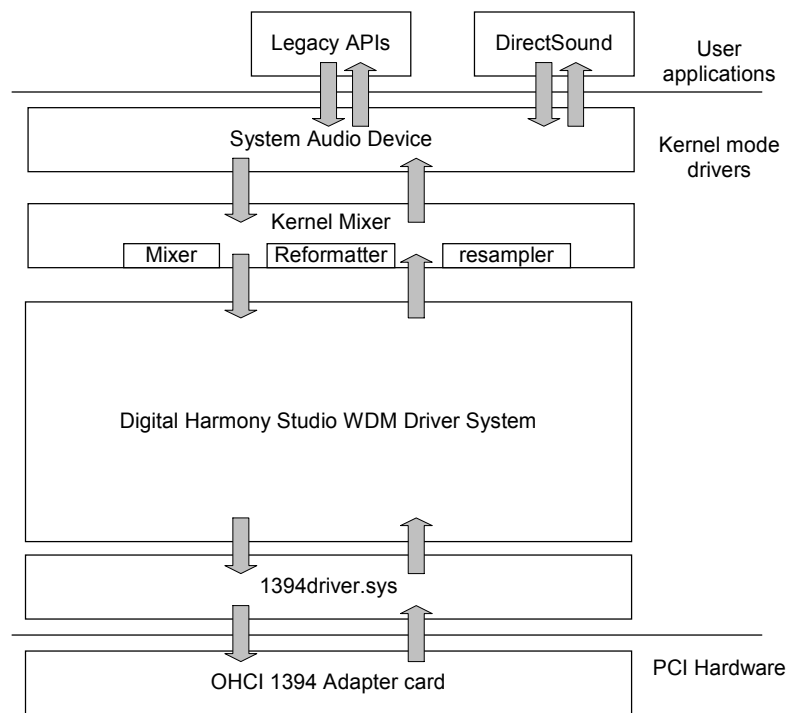

Figure 2: Digital Harmony Studio™ WDM driver system.

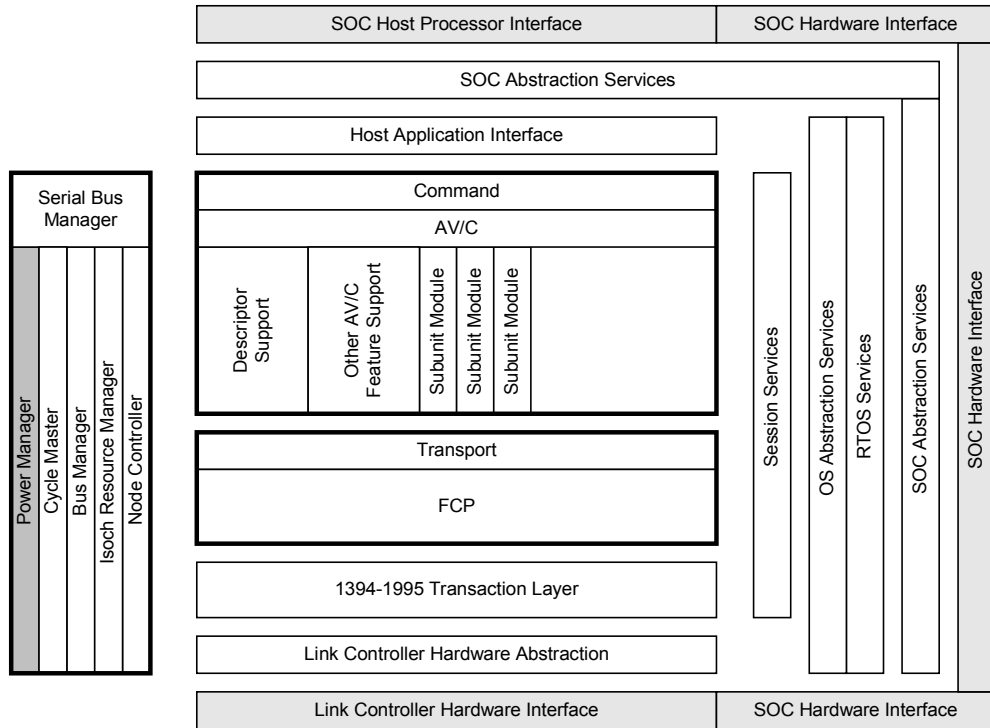

Figure 3: Digital Harmony Studio™ firmware architecture.